

PEK SHORT ELEMENT FEEDER

v1

2013/01/23

The PEK short element feeder serves for mechanical pushing of wood elements during processing. The machine consists of two primary units: the short feeder and belt conveyor. The belt conveyor has been equipped with input bases in the area where the machine operator places elements to be transported. The side bases and upper clamp make it possible to lead transported elements to the short feeder. The short feeder has been equipped with primary units such as a sensor and two hydraulic engines. If an element is within the range of the sensor, the side clamp slides the element to the base and the hydraulic engine installed on the side clamp pushes the element under the second hydraulic engine, which presses the material to the tabletop and transports the element.

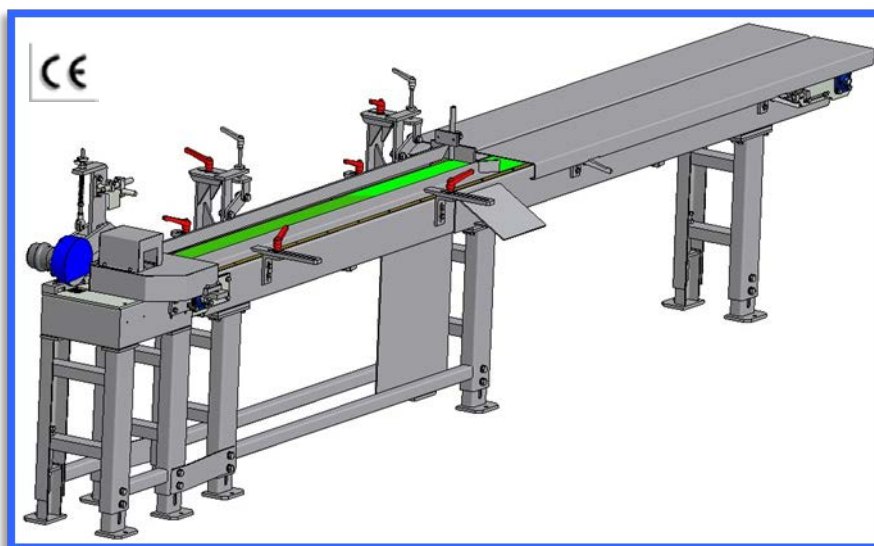

TECHNICAL AND OPERATIONAL DATA:

Element thickness min./max.	mm	20/50
Element width min./max.	mm	50/120
Element length min./max.	mm	450/2400
Working level	mm	870 ± 30
Rate of advance	m/min	30 – 50 Wt%
Engine power	kW	0,75 + 1,5
Electrical supply	V AC	3/N/PE, 400V 50Hz
Control voltage	V DC	24
Noise levels	dBA	75
Machine dimensions:		
- min/max width	mm	700/750
• Height (min / max)	mm	1380/1440
• Length	mm	5240
Machine mass	kg	600